



OWNER'S MANUAL

*C7-100ct*

1-inch (25 mm) Component Tweeter



## C7-100ct: 1-inch (25 mm) Component Tweeter

### INTRODUCTION

Thank you for choosing JL Audio C7 loudspeakers for your automotive sound system. C7 is the pinnacle of JL Audio loudspeaker design, benefitting from patented technologies and our most advanced development tools.

The C7-100ct is a component tweeter designed to deliver unparalleled high-frequency performance. Utilizing a corundum ceramic-coated aluminum alloy diaphragm with a treated silk, s-roll surround, it provides spectacularly detailed reproduction of treble frequencies and outstanding off-axis response. Distortion and non-linearities have been minimized through critical optimization of dynamic motor, diaphragm and suspension behaviors.

Flush and surface mounting fixtures are included to fit a variety of installation applications, as well as a 15 $\mu$ F protection capacitor to guard against damage from transient electrical pops (turn-on/off). This capacitor is not a substitute for high-pass filtering, but must be connected in all installations.

We do not recommend the use of passive crossover networks with C7 loudspeakers. Instead, we recommend a high-quality tuning DSP and a dedicated amplifier channel for each C7 loudspeaker in the system. Precise setup of equalization, delay and crossover filters will ensure optimal in-vehicle performance.

Should you have any questions regarding the instructions in this manual, please contact your authorized JL Audio dealer for assistance, or contact the JL Audio Technical Support Department.

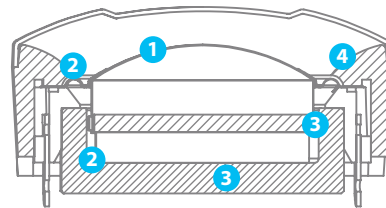
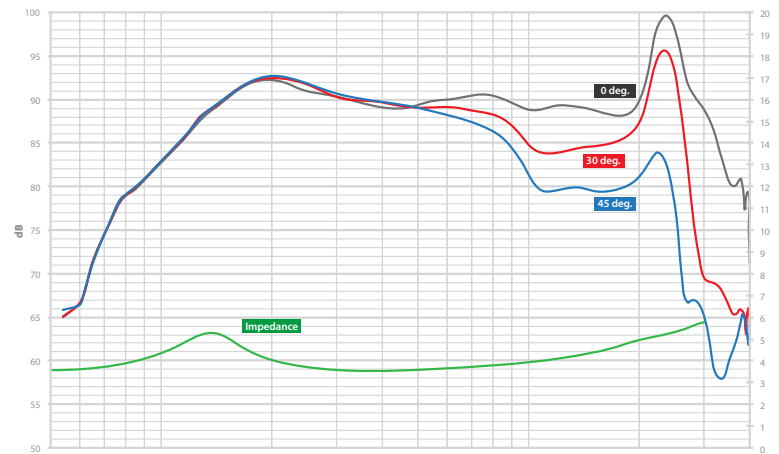

### DESIGN & TECHNOLOGIES

#### Dome Diaphragm:

- 1 Corundum ceramic-coated aluminum alloy diaphragm exhibits high stiffness, very low mass and excellent environmental stability.

#### Suspension Design:

- 2 The diaphragm's motion is centered, sprung and damped by a treated silk, s-roll surround. Ferrofluid in the magnetic gap acts as a rear suspension element in this design. The two combine to provide optimum damping without unduly restricting excursion.

#### Motor Design:

- 3 The C7-100ct employs a high-density magnetic circuit with a high-grade, neodymium magnet, and a specially machined, U-Yoke motor topology. An under-hung voice coil is employed, wound with copper-clad aluminum wire onto an aluminum voice coil former. Motor magnetics have been precisely optimized utilizing advanced FEA tools to lower even order distortion and IMD/AMD.

#### Acoustical Design:

- 4 The shape of the tweeter housing is designed to boost sensitivity in a very specific bandwidth, helping to flatten the frequency response. It also provides control of directivity.



# C7-100ct: Specifications and Crossover Setting Guidelines

## C7-100ct SPECIFICATIONS

**Speaker Type:** Component Tweeter  
**Nominal Diameter:** 1 in. (25 mm)  
**Nominal Impedance (Znom):** 4 ohms  
**Continuous Power Handling:** 100W  
**Recommended Amplifier Power:** 50-150W (RMS)  
**Net Weight:** 0.25 lbs. (110 kg)

### Parameters:

**Voice Coil Resistance (Re):** 3.20 ohms  
**Free Air Resonance (Fs):** 1450 Hz  
**Reference Efficiency (no):** 0.267%  
**Efficiency:** 86.5 dB @ 1W/1m | 92.5 dB @ 1W/0.5m  
**Sensitivity:** 89.5 dB @ 2.83V/1m

### Design Bandwidth:

With 48 dB/octave filters: 3 kHz - 30 kHz  
 With 24 dB/octave filters: 4 kHz - 30 kHz  
 With 12 dB/octave filters: 5 kHz - 30 kHz

## INCLUDED COMPONENT & PARTS

- One (1) C7-100ct 1.0-inch (25 mm) tweeter
- One (1) surface-mount fixture
- One (1) flush-mount fixture
- One (1) #8 metal spring clip (for flush-mounting)
- One (1) #8 flat metal spring nut (for surface-mounting)
- One (1) M4 x 30 mm machine screw
- One (1) #8 x 1.0-inch (25 mm) sheet metal screw
- One (1) 4.7 mm male crimpable connector
- One (1) 2.8 mm male crimpable connector
- One (1) 15 µF tweeter protection capacitor

### C7 3-Way Speaker System

**C7-650cw Woofer**  
 Low-Pass: 24 dB/octave Linkwitz-Riley @ 400 Hz  
 Level Offset: 0 dB

**C7-350cm Midrange**  
 High-Pass: 24 dB/octave Linkwitz-Riley @ 480 Hz  
 Low-Pass: 24 dB/octave Linkwitz-Riley @ 3500 Hz  
 Level Offset: 0 dB

**C7-100ct Tweeter**  
 High-Pass: 24 dB/octave Linkwitz-Riley @ 4500 Hz  
 Level Offset: -1.0 dB

**Please note:** These are recommended starting points for tuning. In-vehicle measurements should be made to optimize the crossover for speaker placement and vehicle acoustics.

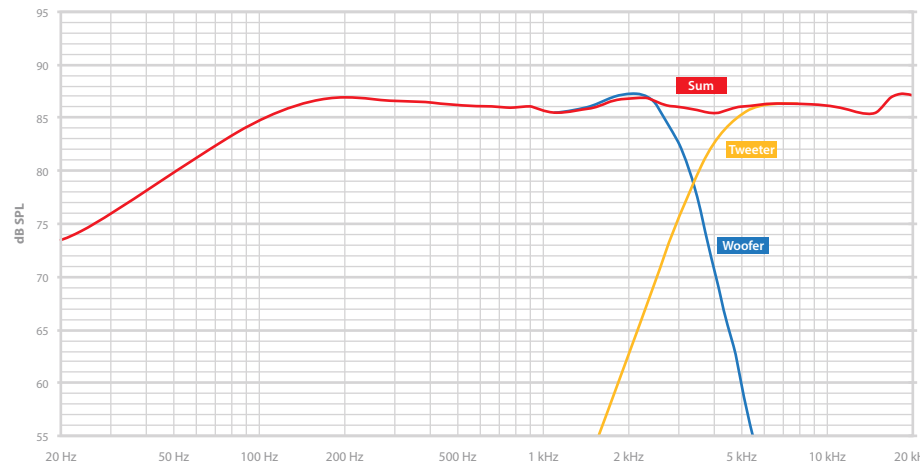
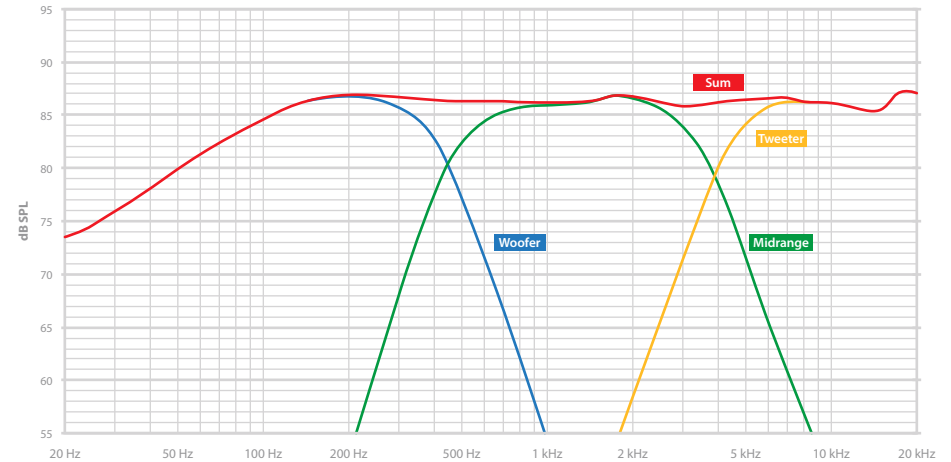

### C7 2-Way Speaker System

**C7-650cw Woofer**  
 Low-Pass: 24 dB/octave Linkwitz-Riley @ 2700 Hz  
 Level Offset: 0 dB

**C7-100ct Tweeter**  
 High-Pass: 24 dB/octave Linkwitz-Riley @ 4000 Hz  
 Level Offset: -1.0 dB

**Please note:** These are recommended starting points for tuning. In-vehicle measurements should be made to optimize the crossover for speaker placement and vehicle acoustics.



## C7-100ct: Dimensions

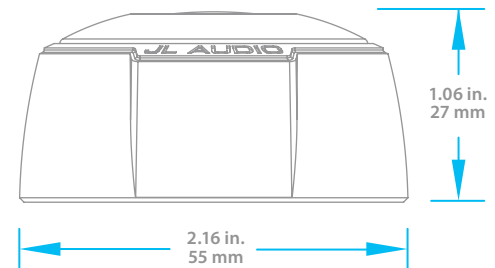
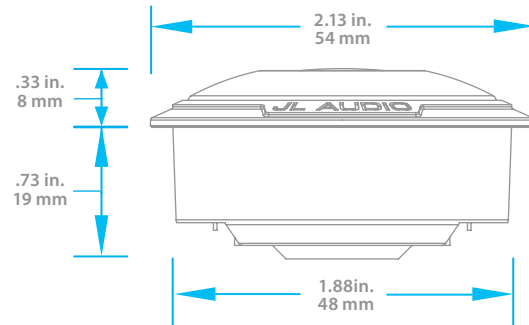



## C7-100ct: Installation

### TWEETER INSTALLATION

C7 tweeters have been designed for surface or flush-mounting. Before choosing a method, carefully inspect the desired mounting location to determine which method will work best.

**Surface-Mount:** uses the supplied surface-mount fixture and requires the drilling of three holes (two for the wires and one for the mounting screw). This application is useful when mounting the tweeters to a panel that has insufficient clearance behind it for the tweeter's magnet structure.

**Flush-Mount:** yields a custom-installed appearance and requires a 1.88-inch (48 mm) diameter hole to be cut in the vehicle panel. At least 1.75-inch (44 mm) of clearance is required behind the tweeter mounting surface for the spring clip and 1-inch machine screw used to mount the fixture. In limited depth applications, it may be necessary to cut down the length of the machine screw, or to use a shorter screw (not supplied). Hand-tighten the machine screw until the fixture is secure, as shown in Diagram C.

### PROTECTION CAPACITOR

A high-quality 15 $\mu$ F protection capacitor is included with the C7-100ct to guard against damage from transient electrical pops (turn-on/off). This capacitor is not a substitute for high-pass filtering and must be connected in all installations. The capacitor's value has been selected so as not to interfere with a properly set active high-pass filter.

The protection capacitor supplied with your C7-100ct should be installed in a dry location and as near as possible to the tweeter. Connect the protection capacitor in-line (series) with the tweeter's positive (+) lead, as shown in Diagram A below. The capacitor is bipolar and may be connected in either direction. Make sure to insulate the capacitor's leads to guard from touching against any exposed metal. Use plastic cable ties or a similar fastener to securely mount the capacitor to avoid coming loose in the event of a collision, sudden jolt or repeated vibrations during normal use. Make sure that your mounting location will not cause damage to wiring or any other vital component of your vehicle.

### TWEETER CONNECTIONS

Run the wire leads from the tweeter mounting locations to the amplifier outputs. Then connect the harness wire leads to the speaker/amplifier outputs and tweeters, observing correct polarity. See Diagram A below for details.

#### !! WARNING

**It is absolutely vital that the protection capacitor is connected, as shown in Diagram A. Failure to connect the protection capacitor as shown will result in damage which is NOT covered under warranty.**

**Diagram A:**  
Tweeter / Protection Capacitor Wiring





## C7-100ct: Surface-Mount Installation

- 1) Remove the vehicle panel and check to ensure that the mounting screw will have adequate clearance.
- 2) Place the surface-mount fixture on the vehicle panel at the desired mounting location and mark the locations of the center mounting screw hole and the approximate center of the left and right semicircular cutouts (for the wires).
- 3) Using a 1/16-inch (1.5 mm) drill bit, drill a pilot hole through the panel at the center screw location.
- 4) Using a 1/4-inch (6 mm) drill bit, drill a hole for each of the tweeter's wires at the locations you marked in step 2.
- 5) Screw the surface-mount fixture to the vehicle panel using the supplied #8 sheet metal screw (hand-tighten) and #8 flat metal spring nut. Feed a tweeter wire through each semicircular cutout in the mounting fixture and the 1/4-inch holes you drilled in the panel.
- 6) To attach the tweeter to the fixture, observe the indented locking slots on the outer edge of the tweeter body and align these with the tabs visible on the inside walls of the fixture. Slide the tweeter into the fixture and secure by pressing down on the tweeter and giving it a small clockwise turn.
- 7) Connect the tweeter's wires to the wire leads from the amplifier, observing correct polarity. Install the protection capacitor as noted on page 5.
- 8) Re-install the vehicle panel, taking care to route the new wiring so as not to interfere with any vehicle mechanisms (window mechanisms, for example).

**Diagram B:**  
Surface-Mount Fixture Installation





## C7-100ct: Flush-Mount Installation

- 1) Remove the vehicle panel and check the desired mounting location to ensure that there is adequate clearance behind the panel for the tweeter's magnet structure and mounting hardware.
- 2) Carefully cut a 1.88-inch (48 mm) diameter hole in the vehicle panel. This will achieve a snug fit and allow the tweeter flange to conceal the cut line.
- 3) Insert the flush-mount fixture from the front of the panel and place the M4 machine screw through the center hole of the fixture.
- 4) From behind the panel, thread the spring clip onto the M4 machine screw and hand-tighten until the fixture is secure.
- 5) Feed a tweeter wire through each semicircular cutout in the fixture from the front of the panel.
- 6) To attach the tweeter to the fixture, observe the indented locking slots on the outer edge of the tweeter body and align these with the tabs visible on the inside walls of the fixture. Slide the tweeter into the fixture and secure by pressing down on the tweeter and giving it a small clockwise turn.
- 8) Connect the tweeter's wires to the wire leads from the amplifier, observing correct polarity. Install the protection capacitor as noted on page 5.
- 9) Re-install the vehicle panel, taking care to route the new wiring so as not to interfere with any vehicle mechanisms (window mechanisms, for example).

**Diagram C:**  
Flush-Mount Fixture Installation

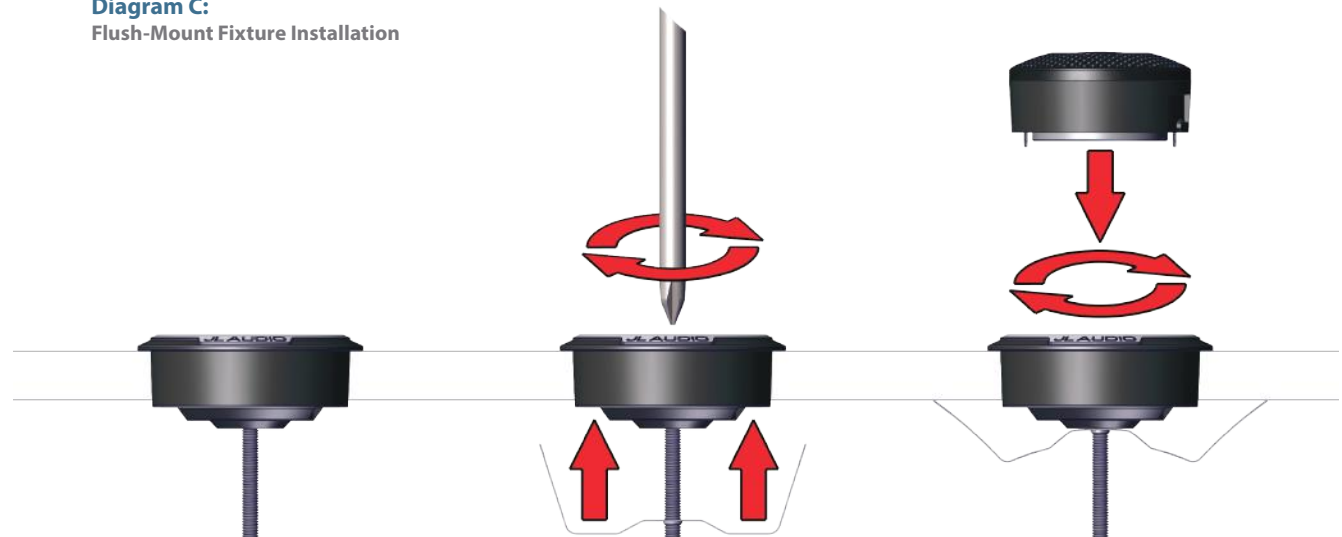



## Limited Warranty

JL AUDIO warrants this speaker to be free of defects in materials and workmanship for a period of one (1) year from the original date of purchase.

This warranty is not transferrable and applies only to the original purchaser of the product from an authorized JL AUDIO dealer. Should service be necessary under this warranty for any reason due to manufacturing defect or malfunction, JL AUDIO will, at its discretion, repair or replace the defective product with new or remanufactured product at no charge.

Damage caused by the following is not covered under warranty: accident, misuse, abuse, product modification or neglect, failure to follow installation instructions, unauthorized repair attempts, misrepresentations by the seller. This warranty does not cover incidental or consequential damages and does not cover the cost of removing or reinstalling the unit(s). Cosmetic damage due to accident or normal wear and tear is not covered under warranty.

Any applicable implied warranties are limited in duration to the period of the express warranty as provided herein beginning with the date of the original purchase at retail, and no warranties, whether express or implied, shall apply to this product thereafter. Some states do not allow limitations on implied warranties, therefore these exclusions may not apply to you. This warranty gives you specific legal rights, and you may also have other rights which vary from state to state.

### If you need service on your JL AUDIO product:

All warranty returns should be sent to JL AUDIO freight prepaid through an authorized JL AUDIO dealer and must be accompanied by proof of purchase (a copy of the original sales receipt). Direct returns from consumers or non-authorized dealers will be refused unless specifically authorized by JL AUDIO with a valid return authorization number. Warranty expiration on products returned without proof of purchase will be determined from the manufacturing date code. Coverage may be invalidated as this date is previous to purchase date. Return only defective components. Non-defective items received will be returned freight-collect. The customer is responsible for shipping charges and insurance in sending the product to JL AUDIO. Freight damage on returns is not covered under warranty. Always include proof of purchase (sales receipt).

### For Service Information in the U.S.A. please call:

JL Audio customer service: (954) 443-1100 during normal business hours (Eastern Time)

### JL Audio, Inc

10369 North Commerce Parkway, Miramar, FL 33025

### International Warranties:

Products purchased outside the United States of America are covered only by that country's distributor and not by JL Audio, Inc.

JL AUDIO® | How we play.®

www.jludio.com

10369 North Commerce Parkway • Miramar, Florida • 33025 • USA

"How we play.", "Ahead of the Curve", "JL Audio" and the JL Audio logo are registered trademarks of JL Audio, Inc.  
"C7" and its respective logo are trademarks of JL Audio, Inc.

©2017 JL Audio, Inc. • For more detailed information please visit us online at [www.jludio.com](http://www.jludio.com). Due to our policy of continuous product development, all specifications are subject to change without notice.